

PARTS MANUAL

**N35ZR2, N40ZR2, N30ZDR2
(E470)**

CUSTOMER EDITION

HYSTER

SECTIONS

1	FRAME
2	ELECTRICAL SYSTEM
3	DRIVE UNIT
4	STEERING SYSTEM
5	BRAKE/ACCELERATOR SYSTEM
6	LOAD WHEEL
7	HYDRAULIC SYSTEM
8	MAST-THREE STAGE
9	CARRIAGE
10	OPTIONS
11	FIELD CONVERSION KITS
12	NUMERICAL INDEX

This Parts Manual is divided into 12 major sections which are listed above. Quick reference to these sections can be made by placing the right thumb on the tab of the desired section, bending the book back and thumbing the pages to the corresponding tab.

**Thanks very much for your reading,
Want to get more information,
Please click here, Then get the complete
manual**

JustClickHere 

NOTE:

**If there is no response to click on the link above,
please download the PDF document first, and then
click on it.**

**Have any questions please write to me:
admin@servicemanualperfect.com**

TABLE OF CONTENTS

DESCRIPTION	PAGE
A	
AC CONTROLLER ASSEMBLY	
36V "EE"	2-41
36V STANDARD AND HIGH PERFORMANCE (→ 12/2014)	2-39
36V STANDARD AND HIGH PERFORMANCE (12/2014 →)	2-40
AFT TRAVEL CONTROL HANDLE ASSEMBLY	2-38
ARMREST AND BACKREST	1-44
ARMREST AND BACKREST INSTALLATION	1-42
ATTACHMENT CABLE	8-32
ATTACHMENT HOSES	8-30
ATTACHMENT SELECTOR VALVE	
DOUBLE REACH	7-24
SINGLE REACH	7-22
ATTACHMENT VALVE AND HOSES	9-30
ATTACHMENTS	
DOUBLE REACH	9-12
SINGLE REACH	9-4
AUDIBLE ALARM	10-12
AUXILIARY PUMP AND MOTOR ASSEMBLY	7-20
B	
BATTERY CONNECTOR	2-56
BATTERY RETAINERS AND ROLLERS	1-48
BATTERY STAND AND PULLER	10-10
BRAKE ASSEMBLY	5-2
C	
CASTER WHEEL ASSEMBLY	
NON-STEERED - 14.5" AND 16.5" BATTERY COMPARTMENT	4-6
STEERED - 14.5" AND 16.5" BATTERY COMPARTMENT	4-2
CASTER WHEEL BUMPERS	10-13
CASTER WHEEL SUSPENSION	
NON-STEERED	4-8
STEERED	4-10
CHAIN GUARD	
DOUBLE REACH	9-16
SINGLE REACH	9-8
CONTACTOR	
→ 12/2014 (FOR 36V STANDARD AND HIGH PERFORMANCE)	2-42
12/2014 → (FOR 36V STANDARD AND HIGH PERFORMANCE)	2-44
CONTROLLER	
CAN I/O AND EPS	2-50
COUNTERBALANCE VALVE	
WITH SIDESHIFT	9-29
WITHOUT SIDESHIFT	9-28
COVERS AND PADS	
FORWARD STANCE	1-38
FORWARD STANCE - WITH AFT CONTROL	1-40
SIDE STANCE	1-36

TABLE OF CONTENTS (continued)

DESCRIPTION	PAGE
D	
DASH DISPLAY	
FORWARD STANCE	2-46
SIDE STANCE	2-47
DECALS	
PAGE 1 OF 2	1-50
PAGE 2 OF 2 - SIDE STANCE	1-52
PAGE 2 OF 2 - FORWARD STANCE	1-54
DIODE ASSEMBLY	
36V IFB PROTECTION	2-55
DRIP SHIELD	8-36
DRIVE WHEEL AND TIRE	3-10
E	
ELECTRICAL SYSTEM	
PAGE 1 OF 2	2-4
PAGE 2 OF 2	2-6
F	
FAN ASSEMBLY AND ATTACHING PARTS	10-20
FLOOR PLATE	
ADJUSTABLE - SIDE STANCE	1-2
ADJUSTABLE - FORWARD STANCE	1-4
FLOOR PLATE AND HEATER CONTROL (ADJUSTABLE)	
SUB-ZERO, FORWARD STANCE - "COMFORT" (→ 6/2015)	1-10
SUB-ZERO, FORWARD STANCE - 36V (→ 6/2015)	1-18
SUB-ZERO, FORWARD STANCE - "COMFORT" (6/2015 →)	1-26
SUB-ZERO, FORWARD STANCE - 36V (6/2015 →)	1-34
SUB-ZERO, SIDE STANCE - "COMFORT" (→ 6/2015)	1-6
SUB-ZERO, SIDE STANCE - 36V (→ 6/2015)	1-14
SUB-ZERO, SIDE STANCE - "COMFORT" (6/2015 →)	1-22
SUB-ZERO, SIDE STANCE - 36V (6/2015 →)	1-30
FORK CAMERA OPTION MODULE ASSEMBLY	10-23
FORKS	9-3
FREE-LIFT	8-18
FREE-LIFT CYLINDER ASSEMBLY	
→ 9/2014	8-22
9/2014 →	8-26
FRONT FRAME	
SIDE-SHIFT AND TILT CARRIAGES	9-26
FUSE BOARD	
36V WITH 12V AND 24V REGULATORS	2-52
H	
HEADLIGHTS	10-16
HEIGHT SENSOR ASSEMBLY	10-4
HEIGHT SENSOR MOUNTING	10-2
HYDRAULIC ARRANGEMENT	
PAGE 1 OF 2	7-2
PAGE 2 OF 2	7-4

TABLE OF CONTENTS (continued)

DESCRIPTION	PAGE
HYDRAULIC HOSES	
DOUBLE REACH	7-28
SINGLE REACH	7-26
HYDRAULIC TANK ASSEMBLY	7-6
I	
IMPACT SENSOR	10-24
J	
JUMPER HARNESS	
DISPLAY - SIDE STANCE	2-37
L	
LASER ASSEMBLY	10-22
LEXAN GUARD	10-28
LIFT MOTOR ASSEMBLY	
"EE"	7-18
24V/36V	7-16
STANDARD AND HIGH PERFORMANCE	7-14
LIFT PUMP AND MOTOR MOUNTING	
WITH "EE" LIFT MOTOR	7-10
WITH 24V/36V LIFT MOTOR	7-9
WITH STANDARD AND HIGH PERFORMANCE LIFT MOTORS	7-8
LIFT PUMP ASSEMBLY	7-12
LOAD BACKREST	9-2
LOAD WHEEL ASSEMBLY	6-2
M	
MAIN LIFT	8-10
MAIN LIFT CYLINDER ASSEMBLY	8-14
MAST CONNECTION	8-4
MAST INSTALLATION	8-2
MASTER DRIVE UNIT	
DRIVE (→ S/N E470N01511L)	3-14
DRIVE (S/N E470N01512L →)	3-20
HOUSING (→ S/N E470N01511L)	3-13
HOUSING (S/N E470N01512L →)	3-19
OUTPUT (→ S/N E470N01511L)	3-15
OUTPUT (S/N E470N01512L →)	3-21
STEERING PARTS (→ S/N E470N01511L)	3-12
STEERING PARTS (S/N E470N01512L →)	3-18
TURNTABLE BEARING (→ S/N E470N01511L)	3-16
TURNTABLE BEARING (S/N E470N01512L →)	3-22
MASTER DRIVE UNIT ASSEMBLY AND ATTACHING PARTS	
→ S/N E470N01511L	3-11
S/N E470N01512L →	3-17
MDU COMPARTMENT DOOR AND FAN	2-48
MULTI-FUNCTION CONTROL HANDLE	
CAGE	2-60
CONTROLLER KIT	2-66

TABLE OF CONTENTS (continued)

DESCRIPTION	PAGE
HANDLE	2-61
HORN	2-62
LEVER	2-63
MINI-JOYSTICK	2-64
MULTI-AXIS CONTROLLER	2-59
PALM GRIP KIT	2-67
SPRING PLATE ASSEMBLY	2-65
MULTI-FUNCTION CONTROL HANDLE ASSEMBLY	2-58
O	
OPERATOR AND OVERHEAD GUARD	1-46
OPERATOR COMPARTMENT LIGHT	10-8
OUTER, INTERMEDIATE, AND INNER MAST	8-6
P	
POWER CABLES	
TRACTION AND LIFT	2-53
TRACTION AND LIFT - ALTERNATE CONFIGURATION	2-54
R	
REACH CYLINDER	9-21
REAR FRAME	9-24
RF HOLSTER AND 12V RECEPTACLE	10-6
RF TERMINAL BRACKET	10-5
RF TERMINAL CONNECTION ASSEMBLY	10-26
S	
SCISSOR	
DOUBLE REACH	9-18
SINGLE REACH	9-10
SENSOR ASSEMBLY	
REDUCED TRAVEL SPEED - FOR EXTENDED CARRIAGE	9-20
SHEAVES	8-34
STEER CONTROLLER AND POWER CABLES	4-22
STEER MOTOR ASSEMBLY	4-12
STEER MOTOR INSTALLATION AND PROXIMITY SENSOR	4-13
STEERING ASSEMBLY	
FORWARD STANCE	4-16
SIDE STANCE	4-14
SIDE STANCE - FIXED	4-18
STEERING ASSEMBLY ATTACHING PARTS	
FORWARD STANCE	4-21
SIDE STANCE	4-20
STROBE LIGHT/ WORKLIGHT	10-18
T	
TELEMETRY KITS	11-2
TELEMETRY OPTIONS	
BUZZER ASSEMBLY	10-36
FORE-AFT	10-34

TABLE OF CONTENTS (continued)

DESCRIPTION	PAGE
SIDE-STANCE	10-32
TILT SENSOR	10-14
TRACTION MOTOR ASSEMBLY	
→ 11/2014	3-2
PAGE 1 OF 6 (11/2014 →)	3-4
PAGE 2 OF 6 (11/2014 →)	3-5
PAGE 3 OF 6 (11/2014 →)	3-6
PAGE 4 OF 6 (11/2014 →)	3-7
PAGE 5 OF 6 (11/2014 →)	3-8
PAGE 6 OF 6 (11/2014 →)	3-9
W	
WIRE HARNESS	
APS2 STEERED CASTER	2-28
DASH - FORWARD STANCE	2-30
FLOORPLATE HEATER	2-23
HEADLIGHTS	2-36
HEATER FREEZER AND ARCTIC (→ 6/2015)	2-24
HEATER FREEZER AND ARCTIC (6/2015 →)	2-26
LIGHTS OPTIONS	2-34
MAIN - 14.5 TO 16.5 INCH BATTERY BOX - PAGE 1 OF 2	2-8
MAIN - 14.5 TO 16.5 INCH BATTERY BOX - PAGE 2 OF 2	2-12
MAIN - 18.5 TO 21.5 INCH BATTERY BOX - PAGE 1 OF 2	2-16
MAIN - 18.5 TO 21.5 INCH BATTERY BOX - PAGE 2 OF 2	2-20
SIDE STANCE	2-32
TELEMETRY OPTIONS - DISPLAY, UPPER	2-68
TELEMETRY OPTIONS - DISPLAY, LOWER	2-69
TELEMETRY OPTIONS - POWER	2-70
TELEMETRY OPTIONS - INTERLOCK	2-71
WIRE HARNESS AND HYDRAULIC HOSES	
DOUBLE REACH	9-14
SINGLE REACH	9-6
WIRE MESH ROOF PROTECTION INSTALLATION	10-30

ABBREVIATIONS QUICK REFERENCE SHEET

Listed below are abbreviations used in parts manuals to denote the following expressions:

TERM	DEFINITION	TERM	DEFINITION
Amp	Amperes	FRE	Freezer Environment
AR	As Required	in.	inches
BDI	Battery Discharge Indicators	LPG	Liquefied Petroleum Gas
BWI	Brush Wear Indicator	MAP	Manifold Absolute Pressure
CE	Communicator End	mm	millimeters
CRE	Corrosive Environment	MSTS	Microprocessor Spark Timing System
D/B	Date Break	NPT	National Pipe Threads
dbA	Decibel "A" Scale	O/S	Oversize
DE	Drive End	PTO	Power Take Off
ECH	Empty Container Handler	RPM	Revolutions per Minute
ECH-3	Empty Container Handler - 3 High Stacking	S/N	Serial Number
ECH-4	Empty Container Handler - 4 High Stacking	TMM	Truck Management Module
ECH-5	Empty Container Handler - 5 High Stacking	UL Type D	Diesel-Powered Safety Rating
ECH-6	Empty Container Handler - 6 High Stacking	UL Type DS	Diesel-Powered Safety Rating
ECH-7	Empty Container Handler - 7 High Stacking	UL Type E	Battery-Powered Safety Rating
ECM	Electronic Control Module	UL Type EE	Battery-Powered Safety Rating
ECN	Engineering Change Notice	UL Type ES	Battery-Powered Safety Rating
EEPROM	Electrically Erasable Programmable Read Only Memory	UL Type G	Gasoline-Powered Safety Rating
EPA	US Environmental Protection Agency	UL Type GS	Gasoline-Powered Safety Rating
EPROM	Electrically Programmable Read Only Memory	UL Type LP	Gas-Powered Safety Rating
		UL Type LPS	LP Gas-Powered Safety Rating
		U/S	Undersize
		UL	Underwriters Laboratory
		V	Volts

HOW TO USE THE ILLUSTRATED PARTS MANUAL

This parts manual describes and illustrates assemblies, subassemblies, and detail parts needed for service replacement.

The different constructions are indicated by keys and footnotes. The callouts correspond to descriptions found on the next page.

HYSTER UNIT CODE D001 NORTH AMERICA 06/2001

TABLE OF CONTENTS

DESCRIPTION	PAGE
AIR INTAKE AND FILTER DIESEL (→ D/B 11/98).....	3-22
AIR INTAKE AND FILTER DIESEL (D/B 11/96 →).....	
AIR INTAKE AND FILTER GASOLINE AND LPG.....	
ALTERNATOR GASOLINE, LPG, AND DIESEL.....	
ALTERNATOR TYPES GS, LPS, AND DS.....	
AUXILIARY FUNCTION TUBE TWO AND THREE STAGE FULL F.....	

SECTION 13 NUMERICAL INDEX

PART NO.	PAGE NO.	ITEM NO.	PART NO.	PAGE NO.	ITEM NO.	PART NO.	PAGE NO.	ITEM NO.	PART NO.	PAGE NO.	ITEM NO.
142	3-4	19	10-13	25	11-27	29	12-31	12	16719	3-36	5
12445	3-32	19	10-17	6	11-31	25	16751	3-16	16849	3-34	21
	3-34	1	10-27	11	11-32	37	16849	3-36	16849	3-36	20
			11-11	6	8-4	45	16863	3-28	16863	3-28	17
			14	13	8-8	34	16865	3-6	16865	3-6	18
			12	6	9-7	9	16882	4-27	16882	4-27	41
			3	17	9-7	19		9-7		9-7	30
			9	10	9-11	9		9-11		9-11	27
			23	46	9-11	17		10-10		10-10	36
			27	46	10-9	21		10-13		10-13	32
			26	14	10-9	28		11-7		11-7	24
			28	14	10-13	16		11-9		11-9	17
			50	14	11-7	19					

SECTIONS

- 1 FRAME
- 2 ELECTRICAL SYSTEM
- 3
- 4
- 5 BRAKE/ACC
- 6
- 7 MAST-TWO STAG
- 8 MAST-THREE STAG
- 9 MAST-TWO STAG
- 10
- 11

TRANSMISSION HOUSING
S/N D001H-2628

KEY:
A: Diesel
B: Gasoline and LPG

ITEM	PART NO.	DESCRIPTION	QTY	
			A	B
		Transmission	1	1
	2022547	Transmission	1	1
	2023329	Case	2	2
1	2021670	Bearing Cap	4	4
2	2023418	Washer	1	1
3	296429	Bolt	2	2
4	293947	Cover	2	2
5	2021390	Colter Pin	4	4
6	1371656	O-Ring	1	1
7	2021329	Plug	4	4
8	2021915	Housing	22	22
9	2021675	Pin	39	39
10	2021336	Bolt	1	1
11	287860	Lockwasher	1	1
12	292682	Hydraulic Pump	1	1
13		Figure 5-3	8	8
14	2021345	Gasket	1	1
15	214364	Bolt	1	1
16	296418	Washer	1	1
17	2021388	Temperature Switch	1	1
18	2021389	Breather	9	9
19	2021383	Dipstick	9	9
20	292515	Bolt	2	2
21	136692	Nut	3	3
22	292527	Bolt	3	2
23	292531	Capscrew	4	4
24	292583	Lockwasher	4	4
25	293637	Bolt	1	1
26	296420	Washer	1	1
	996403	Transmission Kit (Includes Item 7)	1	1
	996405	Transmission Kit (Includes Item 14)	1	1

This Parts Manual is divided into 11 major sections which are listed above. Quick be made by placing the right thumb on the tab of the desired section, bending the pages to the corresponding tab.

© Copy Right Date HYSTER COMPANY See Service Manual for service procedures. 5-15

HOW TO FIND THE DESIRED PART NUMBER

WHEN THE PART NUMBER AND THE NEXT HIGHER ASSEMBLY IS NOT KNOWN:

1. Determine the function and application of the part required. Turn to the Sections Page. Choose the general area of reference most likely to include the part.
2. Turn to the section you chose. Use the Section Table of Contents to determine the assembly which would normally contain the part required. Then locate the part on the assembly breakdown page.

WHEN THE PART NUMBER IS NOT KNOWN AND THE NEXT HIGHER ASSEMBLY IS KNOWN:

3. Determine the assembly the required part is used on. Turn to the Table of Contents (Page i).
4. Locate the assembly the required part is used on and turn to the page indicated for that assembly. Then locate the part on the assembly breakdown page.

WHEN THE PART NUMBER IS KNOWN:

5. Use the Numerical Index (Page 12-1) to find the part number. Turn to the page listed and locate the part as indicated by the item number.

GENERAL:

The assembly breakdowns include part numbers, descriptions, quantities required, keys and footnotes to help in selecting correct parts.

6. Parts Supersession Information. Part numbers that have this history will be displayed in the parts list in the order that they were superseded (from oldest to newest). The superseded part numbers will be shown with a line through them.

Five periods in the PART NO. column (.) indicate that the part is either *Not Serviced Separately* or there is a reference to another figure. A figure reference is denoted by a pointing hand followed by a figure number in the DESCRIPTION column (☞ Figure 10)

7. Keys are used to show two or more similar assemblies, RH and LH assembly parts, etc. Select the appropriate key, "A", "B", "C", "D", or "E" and the corresponding quantity column to find the required parts. Two periods in the QTY column (..) indicate that the part is not used for that assembly.
8. Indented descriptions under the DESCRIPTION column are used to indicate assemblies and

subparts of assemblies. In the example on the previous page, *BEARING CAP* (Item 2) is a subpart of the major assembly *CASE*.

9. Quantities shown are for one assembly. The quantities of the subpart *BEARING CAP* are indicated as two and two. This means two per *CASE* assembly.
10. Serial number breaks identify the most current parts information and are shown as follows:
 - **S/N D001H2628**
Indicates last serial number affected.
 - S/N D001H2629** →
Indicates the first serial number affected.
 - S/N D001H1553** ↔ **S/N D001H3291**
Indicates a range of serial numbers affected.

ECN numbers for pending serial numbers are shown to allow for the inclusion of the most current parts information and are identified as follows:

- **S/N Pending Per ECN 63243**
Indicates a pending serial number for last unit affected.
- S/N Pending Per ECN 63243** →
Indicates a pending serial number for first unit affected.

Date breaks are used to indicate when a change occurred but a subsequent serial number break was not recorded. This is an arbitrary date usually based on the ECN release and are identified as follows:

- **D/B 3/00**
Indicates that a change occurred sometime within that month for the item affected.
- D/B 3/00** →
Indicates that a change occurred sometime within that month for the item affected.
- D/B 3/00** ↔ **D/B 4/00**
Indicates a range of production dates of the item affected.

Contact your local dealer for Hyster lift trucks for serial number information for items with a ECN or a date break.

ORDERING PARTS:

When ordering replacement parts, give the unit serial number, part number, name of part and quantity required.

For any further information on parts, service, or ordering, consult your local dealer for Hyster lift trucks.

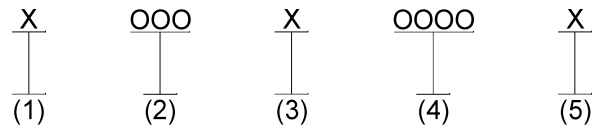
IDENTIFICATION OF TRUCK SERIAL NUMBERS

- (1) and (2) The first letter and three numbers indicate the truck unit code.
- (3) The second letter indicates the plant of manufacture.
- (4) The four or five digit number indicates the production sequence number of the truck.
- (5) The final letter indicates the year of manufacture starting with "A" in 1957, 1980, and 2003.
The letters "I", "O", and "Q" will not be used.

For pending serial numbers contact your local dealer for Hyster lift trucks.

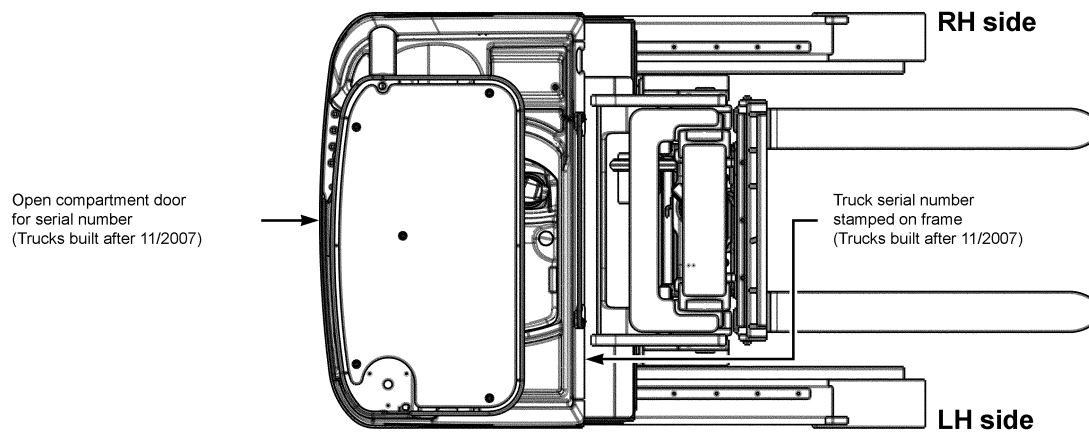

BP990007

Parts referred to in this book as right or left hand parts are in accordance with the illustration above.

IDENTIFICATION OF MAST SERIAL NUMBERS

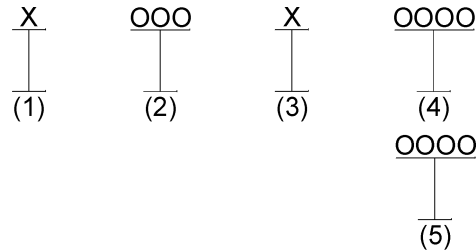

- (1) and (2) The first letter and number indicates the mast unit code.
- (3) The second letter indicates the plant of manufacture.
- (4) The four or five digit number indicates the production sequence number of the mast.
- (5) Carriage travel in millimeters stamped just below the serial number.

Mast Group identification consists of mast unit code (1) and (2) plus carriage travel (5).

For pending production sequence numbers contact your local dealer for Hyster lift trucks.

LIFT EQUIPMENT IDENTIFICATION

1. Fork part number, capacity rating, plant code letter, and date of manufacture are stamped approximately six inches below the top of most forks.
2. The carriage group number is stamped on the right hand side of the top crossmember (pin type) or on the back of the right hand end of the bottom crossmember (hook type). A date code has two letters in line with or below the carriage group number.
3. The mast identification number has a unit code, a letter indicating the plant of manufacture, and a serial number. Underneath the production sequence number is a four digit number that indicates the carriage travel in millimeters.
4. Tilt and lift cylinder group numbers are stamped on the cylinder shell.

Always refer to the group, serial, or part number when ordering service parts.

Modification of masts and carriages by SPED (Special Products Engineering Department) are identified by a model prefix code beginning with the letter "S". contact your dealer for Hyster lift trucks for information on these assemblies.

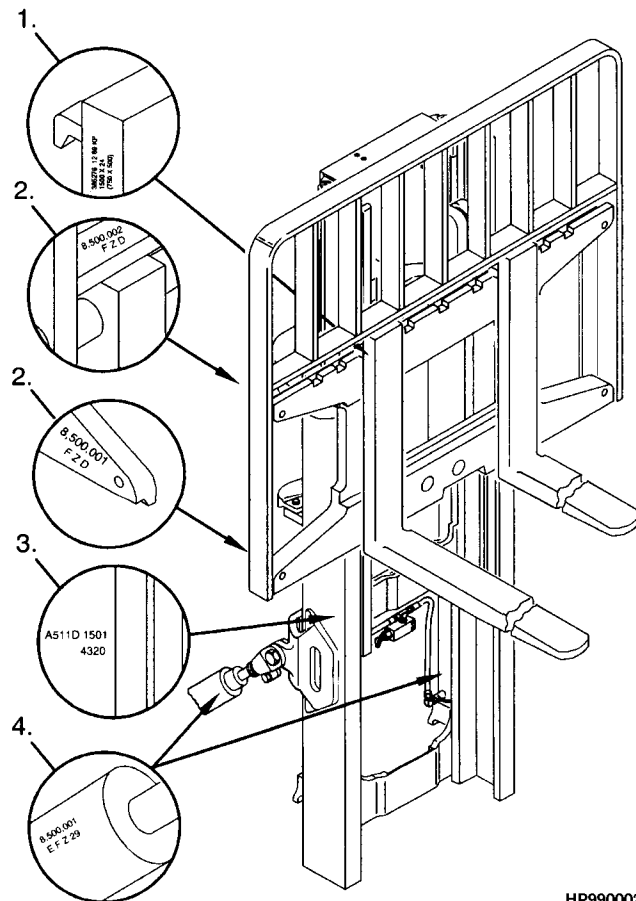

HP990002

IDENTIFICATION OF ATTACHMENT AND SIDE-SHIFT CARRIAGE SERIAL NUMBERS

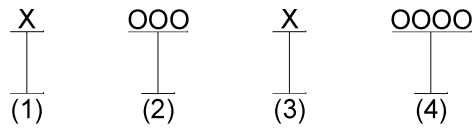

- (1) and (2) The first letter and three numbers indicate the attachment unit code.
- (3) The second letter indicates the plant of manufacture.
- (4) The four or five digit number indicates the production sequence number.
- For pending production sequence numbers contact your local dealer for Hyster lift trucks.

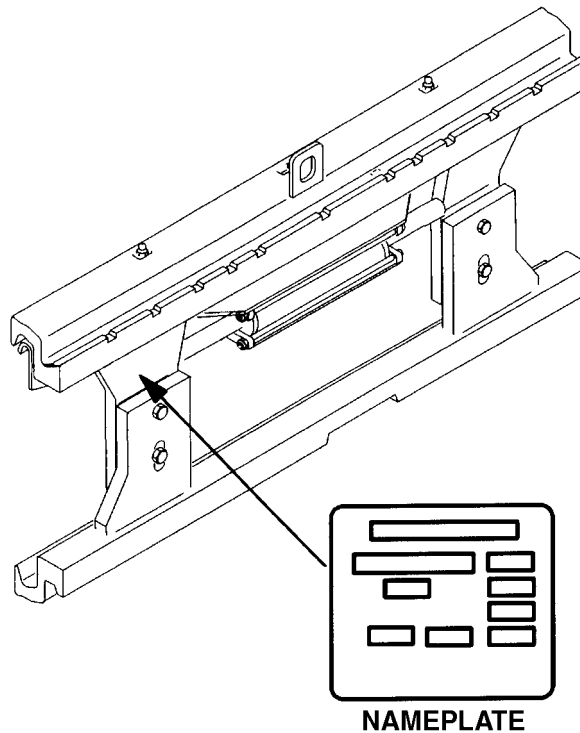

HP990003

Side-shift carriages and attachments have nameplates. Use the serial number found on the nameplate to identify the attachment.

Always refer to the group, serial, or part number when ordering service parts.

Modifications of attachments and side-shift carriages by SPED (Special Products Engineering Department) are identified by a model prefix code beginning with the letter "S". Contact your dealer for Hyster lift trucks for information on these assemblies.

PUBLICATIONS

Every new lift truck is provided with an OPERATING MANUAL. This manual has information that the operator must know for inspection and operation of the lift truck.

SERVICE MAINTENANCE MANUALS, which provide service and overhaul procedures, and PARTS

MANUALS with complete replacement part identification, are available at a nominal fee from your Hyster dealer to assist users in effectively maintaining Hyster lift trucks in a safe, useful condition. See the list below for information on ordering specific publications for this model lift truck.

PUBLICATION	HYSTER PART NUMBER
Operating Manual.....	4074892
Service Manual (Complete).....	4075010
Parts Manual.....	4075011

1

FRAME

**SECTION 1
FRAME**

DESCRIPTION	PAGE
ARMREST AND BACKREST	1-44
ARMREST AND BACKREST INSTALLATION	1-42
BATTERY RETAINERS AND ROLLERS	1-48
COVERS AND PADS	
FORWARD STANCE	1-38
FORWARD STANCE - WITH AFT CONTROL	1-40
SIDE STANCE	1-36
DECALS	
PAGE 1 OF 2	1-50
PAGE 2 OF 2 - SIDE STANCE	1-52
PAGE 2 OF 2 - FORWARD STANCE	1-54
FLOOR PLATE	
ADJUSTABLE - SIDE STANCE	1-2
ADJUSTABLE - FORWARD STANCE	1-4
FLOOR PLATE AND HEATER CONTROL (ADJUSTABLE)	
SUB-ZERO, FORWARD STANCE - "COMFORT" (→ 6/2015)	1-10
SUB-ZERO, FORWARD STANCE - 36V (→ 6/2015)	1-18
SUB-ZERO, FORWARD STANCE - "COMFORT" (6/2015 →)	1-26
SUB-ZERO, FORWARD STANCE - 36V (6/2015 →)	1-34
SUB-ZERO, SIDE STANCE - "COMFORT" (→ 6/2015)	1-6
SUB-ZERO, SIDE STANCE - 36V (→ 6/2015)	1-14
SUB-ZERO, SIDE STANCE - "COMFORT" (6/2015 →)	1-22
SUB-ZERO, SIDE STANCE - 36V (6/2015 →)	1-30
OPERATOR AND OVERHEAD GUARD	1-46